

इंटरनेट

मानक

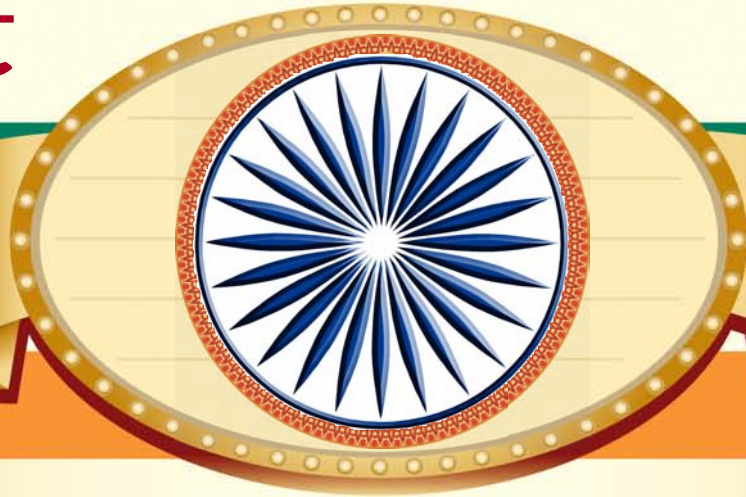

### Disclosure to Promote the Right To Information

Whereas the Parliament of India has set out to provide a practical regime of right to information for citizens to secure access to information under the control of public authorities, in order to promote transparency and accountability in the working of every public authority, and whereas the attached publication of the Bureau of Indian Standards is of particular interest to the public, particularly disadvantaged communities and those engaged in the pursuit of education and knowledge, the attached public safety standard is made available to promote the timely dissemination of this information in an accurate manner to the public.

“जानने का अधिकार, जीने का अधिकार”

Mazdoor Kisan Shakti Sangathan

“The Right to Information, The Right to Live”

“पुराने को छोड़ नये के तरफ”

Jawaharlal Nehru

“Step Out From the Old to the New”

IS 3348 (1965): Specification for fibre insulation boards  
[CED 20: Wood and other Lignocellulosic products]

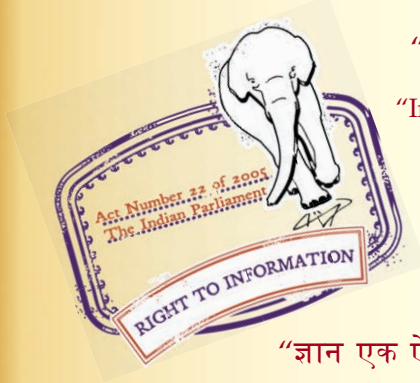

“ज्ञान से एक नये भारत का निर्माण”

Satyanarayan Gangaram Pitroda

“Invent a New India Using Knowledge”



“ज्ञान एक ऐसा खजाना है जो कभी चुराया नहीं जा सकता है”

Bhartrhari—Nitiśatakam

“Knowledge is such a treasure which cannot be stolen”



BLANK PAGE



IS : 3348 - 1965

Reaffirmed 2009

*Indian Standard*

**SPECIFICATION FOR  
FIBRE INSULATION BOARDS**

( Third Reprint DECEMBER 1996)

UDC 691.147

© *Copyright* 1965

**BUREAU OF INDIAN STANDARDS**  
MANAK BHAVAN, 9 BAHADUR SHAH ZAFAR MARG  
NEW DELHI 11 0002

**Gr 5**

*December* 1965

# Indian Standard

## SPECIFICATION FOR FIBRE INSULATION BOARDS

Wood Products Sectional Committee, BDC 20

<i>Chairman</i>	<i>Representing</i>
DR. D. NARAYANAMURTI	Indian Plywood Industries Research Association, Bangalore
<i>Members</i>	
ASSISTANT DIRECTOR ( SPECIFICATION ), RESEARCH, DESIGN AND STANDARDS ORGANIZATION	Railway Board ( Ministry of Railways )
SHRI P. BARUA	Forest Department, Government of Assam
DIRECTOR, SCIENTIFIC RESEARCH	Naval Headquarters, Ministry of Defence
SHRI M. J. GRIFFITHS	Indian Tea Association, Calcutta
SHRI A. J. CAMERON ( Alternate )	
DR. JOSEPH GEORGE	Central Building Research Institute ( CSIR ), Roorkee
SHRI SHIVA MOHAN SINGH ( Alternate )	
SHRI A. K. KADERKUTTY	The Western India Plywoods Ltd., Baliapatam
SHRI N. S. KALKINI	Forest Department, Government of Mysore
SHRI K. K. NAIDU ( Alternate )	
SHRI R. C. KAUSHIK	Forest Research Institute & Colleges, Dehra Dun
SHRI G. L. KEDIA	Jay Shree Tea & Industries Ltd., Calcutta
SHRI K. K. KELA ( Alternate )	
SHRI B. K. KHATTAN	The Plywood Manufacturers' Association of India, Calcutta
SHRI G. L. KEDIA ( Alternate )	
SHRI K. S. LAULY	Southern India Plywood Manufacturers' Association, Calicut
SHRI V. J. NEDUNGADI ( Alternate )	
SHRI J. S. MATHARU	Directorate General of Technical Development
DR. A. N. NAYER	Defence Production ( DGI ), Ministry of Defence
SHRI R. N. VAIDYA ( Alternate )	
PRESIDENT	Forest Research Institute & Colleges, Dehra Dun
SHRI RABINDER SINGH	National Buildings Organization ( Ministry of Works & Housing )
ASSISTANT DIRECTOR (T) ( Alternate )	
SHRI S. RAMAMRITHAM	Directorate General of Civil Aviation ( Ministry of Transport )
SHRI N. K. SHARMA	Forest Department, Government of Madhya Pradesh
LT-COL G. B. SINGH	Engineer-in-Chief's Branch, Army Headquarters
SHRI VASANTHA RAO ( Alternate )	

( Continued on page 2 )

BUREAU OF INDIAN STANDARDS  
MANAK BHAVAN, 9 BAHADUR SHAH ZAFAR MARG  
NEW DELHI 110002

**IS : 3348 - 1965**

(Continued from page 1)

<i>Members</i>	<i>Representing</i>
SHRI A. V. SUBBA RAO SHRI P. K. CHOUTHROY ( <i>Alternate</i> )	Assam Railways and Trading Co Ltd., Margherita
SUPERINTENDING SUBVEYOR OF WORKS	Central Public Works Department
SHRI M. SWARUP SHRI H. THOMSON	Paharpur Timbers Private Ltd., Calcutta Plywood Products, Sitapur
SHRI G. W. M. WHITTLE ( <i>Alternate</i> ) DR H. C. VISVESVARAYA, Deputy Director (Civil Eng)	Director, ISI ( <i>Ex-officio Member</i> )
	<i>Secretary</i>
	SHRI S. P. RAMAN Assistant Director (Civil Eng), ISI

**Fibre Building Boards Subcommittee, BDC 20 : 6**

<i>Convener</i>	
DR D. NARAYANAMURTI	Indian Plywood Industries Research Association, Bangalore
	<i>Members</i>
ASSISTANT DIRECTOR (SPECIFICATION), RESEARCH, DESIGN AND STANDARDS ORGANIZATION	Railway Board (Ministry of Railways)
ASSISTANT DIRECTOR STANDARDS (CARRIAGE) ( <i>Alternate</i> )	
SHRI N. C. JAIN	Forest Research Institute & Colleges, Dehra Dun
SHRI G. R. JOLLY	Anil Hardboards Ltd, Bombay
DR JOSEPH GEORGE	Central Building Research Institute (CSIR), Roorkee
SHRI SHIVA MOHAN SINGH ( <i>Alternate</i> )	
SHRI K. S. LAULY	Indian Plywood Manufacturing Co Ltd., Bombay
SHRI J. S. MATHARU	Directorate General of Technical Development
DR A. N. NAYER	Defence Production (DGI), Ministry of Defence
SHRI A. K. RAMACHANDRAN	The Western India Plywood Ltd, Baliapatam
SHRI H. THOMSON	Plywood Products, Sitapur

**AMENDMENT NO. 1    APRIL 1978**  
**TO**  
**IS : 3348 - 1965 SPECIFICATION FOR**  
**FIBRE INSULATION BOARDS**

**Alterations**

( *Pages 6 and 7, clause 4.5* )— Substitute the following for the existing clause:

**'4.5 Sound Absorption**— The sound absorption coefficient when determined by the standing wave method shall be as follows:

<i>Frequency</i> <i>c/s</i>	<i>Absorption Coefficient</i> <i>Min</i>
125	0.1
250	0.1
500	0.2
1 000	0.3
2 000	0.5

**4.5.1** The sound absorption coefficient may be determined by reverberation chamber method, the criteria of acceptance in which case shall be agreed upon, between the purchaser and the supplier.'

( *Page 6, foot-note with '\*' mark* )— Delete.

( *Page 7, foot-note with '\*' mark* )— Delete.

( *Page 8, foot-note with '\*' mark* )— Delete the words '( *under preparation* )'.

( *Page 10, clause 9.5* )— Substitute the following for the existing clause:

**'9.5 Test for Sound Absorption**— The same test pieces, 30 × 30 cm, for thermal conductivity may be used for sound absorption before performing the former test. The test shall be done as mentioned under 4.5.'

( *Page 16, clause E-2.2, line 1* )— Substitute '15 mm' for '2.2 mm'.

( BDC 20 )

**AMENDMENT NO. 2 JUNE 2005  
TO  
IS 3348 : 1965 SPECIFICATION FOR  
FIBRE INSULATION BOARDS**

( Page 4, clause 3 ) — Substitute the following for the existing

**3 DIMENSIONS AND TOLERANCES**

**3.1** The dimensions of fibre insulation boards shall be as follows

Length in mm    3 600, 3 000, 2 700, 2 400, 2 100, 1 800, 1 500, 1 200,  
1 000, 900, 600, 450 and 300

Width in mm    1 800, 1 500, 1 200, 1 000, 900, 600, 450 and 300

**3.2 Thickness**

The thickness of fibre insulation boards shall be 9 mm, 12 mm, 18 mm and 25 mm

NOTE — Any other dimension (length, width and thickness) as agreed to between the manufacturer and the purchaser may also be used

**3.3 Tolerances**

The tolerances on the nominal sizes of finished boards shall be as follows

<i>Dimensions</i>	<i>Tolerances</i>
Length	+ 6 mm - 0 mm
Width	+ 3 mm - 0 mm
Thickness	± 5 percent
Edge straightness	2 mm per 1 000 mm or 0.2 percent
Squareness	2 mm per 1 000 mm or 0.2 percent

( CED 20 )

Reprography Unit, BIS, New Delhi, India

*Indian Standard*  
SPECIFICATION FOR  
FIBRE INSULATION BOARDS

0. FOREWORD

**0.1** This Indian Standard was adopted by the Indian Standards Institution on 17 September 1965, after the draft finalized by the Wood Products Sectional Committee had been approved by the Civil Engineering Division Council.

**0.2** Fibre insulation boards of various types are being used in increasing quantities as an insulation material and are also finding use as acoustic boards. This standard is intended to classify the various types of insulation boards and to lay down the essential requirements for such type of boards for general purposes.

**0.3** In the formulation of this standard due weightage has been given to international co-ordination among the standards and practices prevailing in different countries in addition to relating it to the practices in this field in this country. This has been met by basing the standard on the following publications:

11-GP-2 Fibreboard; insulating. Canadian Government Specifications Board.

JIS A-5905-1961 Insulation fibreboards. Japanese Standards Association.

**0.4** For the purpose of deciding whether a particular requirement of this standard is complied with, the final value, observed or calculated, expressing the result of a test or analysis, shall be rounded off in accordance with IS : 2-1960\*. The number of significant places retained in the rounded off value should be the same as that of the specified value in this standard.

---

**1. SCOPE**

**1.1** This standard covers fibre insulating boards made of wood or sugarcane fibre.

\*Rules for rounding off numerical values (*revised*).

## IS : 3348 - 1965

1.2 It also covers the following special types of fibre insulation boards:

- a) Bitumen-Bonded Fibre Insulating Board, and
- b) Flame-Retardant Treated Fibre Insulating Board.

## 2. TERMINOLOGY

2.0 For the purpose of this standard, the following definitions shall apply.

**2.1 Fibre Insulation Board** — Insulation board of a homogeneous or laminated nature, made of wood or any other lignocellulosic material, like bagasse. It has generally a density not exceeding  $0.4 \text{ kg/cm}^3$ , a nominal thickness of not less than 9 mm and a thermal conductivity not exceeding  $5.6 \text{ k cal}\cdot\text{cm/m}^2\cdot\text{h}^\circ\text{C}$  ( or  $0.65 \text{ mW/cm}\cdot\text{deg}$  ).

**2.2 Bitumen-Bonded Fibre Insulation Board** — Insulation board generally made of wood fibre or sugarcane fibre, and manufactured either by bitumen sizing at the pulp stage, or impregnated bitumen in the finished board, or with multiple layers of insulation board bonded together with bitumen to a thickness of not less than 12 mm.

**2.3 Flame-Retardant Treated Fibre Insulation Board** — Insulating board that has been treated to reduce the rate of flame spread across the surface.

## 3. DIMENSIONS AND TOLERANCES

3.1 The boards shall be rectangular and, unless otherwise specified, shall have square edges. The dimensions shall be subject to the tolerances given in Table 1. The mean thickness shall be determined by the method described in Appendix A.

## 4. REQUIREMENTS

**4.1 Density** — The mean density of the boards, determined by the method described in Appendix A, shall not exceed  $0.4 \text{ g/cm}^3$ .

**4.2 Transverse Strength** — When determined in the manner described in Appendix B, the mean breaking load, of the eighteen rectangular test pieces marked  $X_1$ ,  $X_2$  and  $X_3$  and of the eighteen rectangular test pieces marked  $L_1$ ,  $L_2$  and  $L_3$  in Fig. 1A, 1B and 1C, each test piece measuring  $20 \times 10 \text{ cm}$ , shall be not less than the appropriate values given in Table 2, the mean of each group being determined separately.

**4.3 Water Absorption** — The mean water absorption of six rectangular test pieces, marked 'W' in Fig. 1A, 1B and 1C, each measuring  $20 \times 10 \text{ cm}$  when determined in the manner described in Appendix C shall be not more than the appropriate values given in Table 3.

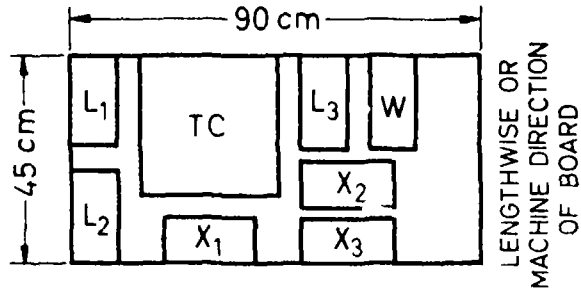
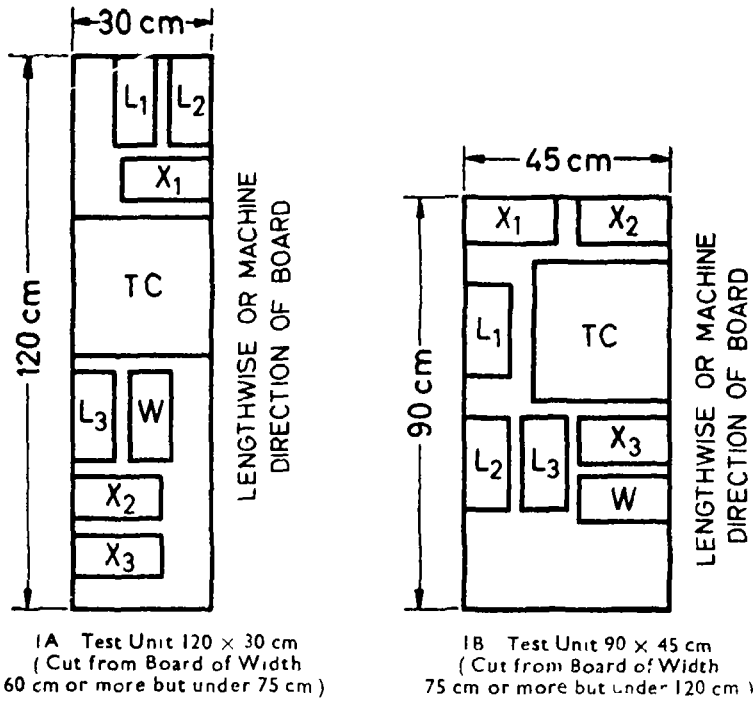

- TC - Test piece (30 × 30 cm) for thermal conductivity test  
 X<sub>1</sub>, X<sub>2</sub>, X<sub>3</sub> - Test pieces (20 × 10 cm) taken across width of board for strength test  
 L<sub>1</sub>, L<sub>2</sub>, L<sub>3</sub> - Test piece (20 × 10 cm) taken along length of board for strength test  
 W - Test piece (20 × 10 cm) for water absorption test

FIG. 1 CUTTING DIAGRAM FOR OBTAINING TEST PIECES FROM THE TEST UNIT

TABLE 1 DIMENSIONS AND TOLERANCES

( Clause 3.1 )

TYPE OF BOARD	NOMINAL THICKNESS	TOLERANCE ON THICKNESS	LENGTH	WIDTH	TOLERANCE ON LENGTH AND WIDTH
	mm	mm	cm	cm	
Fibre insulation board, ordinary or flame-retardant type	9	$\pm 0.75$	365, 300,	180, 150,	120 cm and
	12	$\pm 0.75$	270, 240,	120, 100,	below:
	18	$\pm 1.00$	210, 180,	90, 60,	$\pm 3$ mm
	25	$\pm 1.25$	150, 120,	45 and 30	Above 120 cm : $\pm 6$ mm
Bitumen-bonded fibre insulation board	9	$\pm 0.50$	60, 45		
	12	$\pm 0.50$	and 30		
	18	$\pm 0.75$			
	25	$\pm 0.75$			

TABLE 2 MINIMUM MEAN BREAKING LOAD

( Clause 4.2 )

TYPE OF BOARD	NOMINAL THICKNESS	MINIMUM MEAN BREAKING LOAD	APPROX MODULUS OF RUPTURE FOR NOMINAL THICKNESS
	mm	kg	kg/cm <sup>2</sup>
Fibre insulation board, ordinary or flame-retardant type	9	7.2	20
	12	12.8	20
	18	23.0	16
	25	44.0	16
Bitumen-bonded fibre insulation board	9	13.0	38
	12	23.0	38
	18	45.0	32
	25	86.0	32

**4.4 Thermal Conductivity** — The thermal conductivity of fibre insulation boards, when determined by either of the methods prescribed in Appendix D, shall be not more than 5.6 kcal·cm/m<sup>2</sup>·h°C ( or 0.65 mW/cm·deg ).

**4.5 Sound Absorption** — The sound absorption coefficient by the standing wave method as determined according to Appendix C of IS : 3308\*

\*Specification for wood wool building slabs ( under preparation ).

shall be as follows for fibre insulation boards:

<i>Frequency</i> <i>c/s</i>	<i>Absorption Coefficient</i> <i>Min</i>
125	0.1
250	0.1
500	0.2
1 000	0.3
2 000	0.5

NOTE — Till such time IS . 3308\* is printed the details with regard to testing for sound absorption test shall be as agreed to between the purchaser and the supplier.

**TABLE 3 WATER ABSORPTION**

( Clause 4.3 )

TYPE OF BOARD	NOMINAL THICKNESS mm	MAXIMUM MEAN WATER ABSORPTION AT 27° ± 2°C
Fibre insulation board, ordinary or flame- retardant type	{ 9	30
	{ 12	30
	{ 18	25
	{ 25	25
Bitumen-bonded fibre insulation board	{ 9	25
	{ 12	25
	{ 18	20
	{ 25	20

## 5. SPECIAL REQUIREMENT FOR FLAME-RETARDANT FIBRE INSULATING BOARDS

5.1 For the flame-retardant treated fibre insulation board, the average maximum area of char, when tested for surface spread of flame by the method specified in Appendix E, shall not be more than 75 cm<sup>2</sup>.

5.1.1 In the case of flame-retardant fibre insulation boards treated on one face only, the face which is treated shall be clearly indicated.

NOTE 1 — Attention is drawn to the possibility that boards which have been treated or processed for flame-retardant properties may require the application of special type sealers or primers prior to decoration. Possible reduction of original flame-retardant properties after applying sealers, primers or final decoration should be considered.

NOTE 2 — The purchaser should clearly state his requirements in respect of the type of board, together with the requirements for flame-retardant treatment.

NOTE 3 — The manufacturer should be consulted about the possible effect of the treatment on the sound absorption or other physical properties of the board, where these are important

\*Specification for wood wool building slabs ( *under preparation* ).

**IS : 3348 - 1965**

## **6. MANUFACTURER'S CERTIFICATE**

**6.1** If so desired by the purchaser, the manufacturer shall provide a certificate to the effect that the boards conform in all respects to this standard. In cases where tests are made by the manufacturer at regular intervals and records of such tests are made available to the purchaser, the latter may, at his discretion, accept such test records instead of the certificate. Manufacturer's certificate will not be necessary if the board bears the ISI Certification Mark ( *see 7.1.1* ).

## **7. MARKING**

**7.1** Each insulation board shall be legibly and indelibly marked with the following information:

- a) Name of manufacturer or trade-mark, if any;
- b) Date of manufacture;
- c) Type of board;
- d) Treated face or faces in the case of flame-retardant treated fibre insulation board ( *see 5.1.1* ); and
- e) Size and thickness of board.

### **7.2 BIS Certification Marking**

The product may also be marked with Standard Mark.

**7.2.1** The use of the Standard Mark is governed by the provisions of the Bureau of Indian Standards Act, 1986 and the Rules and Regulations made thereunder. The details of conditions under which the licence for the use of Standard Mark may be granted to manufacturers or producers may be obtained from the Bureau of Indian Standards.

## **8. SAMPLING**

**8.1** Not less than six boards from each lot shall be taken at random to the satisfaction of the testing authority. As an alternative, detailed sampling procedure as in 7 of IS : 3129-1965\* may also be used. From each board a length shall be cut as determined by the width of the board in accordance with Table 4. From each such length a rectangular test unit of the appropriate size shown in Table 4 shall be cut in such a way that no part of the unit lies within 15 cm of the edges of the piece from which it is cut.

**8.1.1** These units shall constitute the sample under test.

---

\*Specification for particle board for insulation purposes ( *under preparation* ).

**8.2** The recommended method of marking and cutting the test units to obtain the test pieces required for the various tests described in Appendices A to E is shown in Fig. 1A, 1B and 1C.

**TABLE 4 DIMENSIONS OF TEST UNITS**

( Clause 8.1 )

WIDTH OF BOARD	LENGTH OF BOARD REQUIRED	DIMENSIONS OF TEST UNITS
cm	cm	cm
60 up to but not including 75	150	120 × 30
75 up to but not including 120	120	90 × 45
120 and more	75	90 × 45

**NOTE 1** — The units are to be conditioned, weighed and measured for the determination of density ( Appendix A ) before being cut again to provide test pieces on which strength and other properties are measured.

**NOTE 2** — The description in Appendices A to C are worded in terms of six test units but the number may, if desired, be increased by agreement between the parties concerned.

## 9. TESTS

**9.1 Preparation and Conditioning of Test Pieces** — The test units shall be conditioned by being freely exposed for at least 48 hours to the atmosphere of a well-ventilated room, or, in case of dispute, and in any event if either the purchaser or the manufacturer so specifies as these shall be conditioned in an atmosphere maintained at a relative humidity of  $65 \pm 5$  percent, at a temperature of  $27 \pm 2^\circ\text{C}$  until the weight is substantially constant. The method of conditioning adopted is recorded with the test results.

**9.1.1** The test units shall then be weighed and measured for the determination of the density as described in Appendix A, following which the required numbers of test pieces shall be prepared with a fine saw. The saw cuts are made parallel to the edges of the board and normal to the surface.

**9.1.2** The test pieces shall be marked and cut from the test units in the manner given in Fig. 1A, 1B and 1C according to the width of the unit.

**9.2 Transverse Strength Test** — For the transverse strength test ( Appendix B ), six rectangular test pieces each  $20 \pm 0.15$  cm  $\times$   $10 \pm 0.15$  cm are cut with all edges square, from each of the six test units. Three of these pieces, marked  $L_1$ ,  $L_2$  and  $L_3$  in Fig. 1A, 1B and 1C, shall be cut with the longer dimension parallel to the lengthwise or

**IS : 3348 - 1965**

machine direction of the board and three, marked  $X_1$ ,  $X_2$  and  $X_3$  in Fig. 1A, 1B and 1C at right angles to this direction.

**9.3 Water Absorption Test** — For the water absorption test ( Appendix C ), one further test piece marked 'W' in Fig. 1A, 1B and 1C,  $20 \pm 0.15$  cm  $\times$   $10 \pm 0.15$  cm, shall be prepared in the same manner, as described in 9.2, from each of the six test units. The edges of these test pieces are smoothed with sand-paper, but not sealed.

**9.4 Thermal Conductivity Test** — For the thermal conductivity test ( Appendix D ), a test piece marked 'TC' in Fig. 1A, 1B and 1C,  $30 \times 30$  cm, shall be prepared from each of four test units.

**9.5 Test for Sound Absorption** — This shall be done in accordance with Appendix C of IS : 3308\*. The same test pieces,  $30 \times 30$  cm, for thermal conductivity test may be used for sound absorption before performing the former test.

**9.6 Test for Flame Spread** — Test for flame spread shall be done in accordance with the method specified in Appendix E. The specimen shall be  $30 \times 30$  cm size and not less than three test specimens shall be tested for this purpose.

## **APPENDIX A**

( *Clauses 3.1, 4.1, 8.2 and 9.1.1* )

### **DETERMINATION OF THICKNESS AND DENSITY**

#### **A-1. DETERMINATION OF THICKNESS**

**A-1.1** The length, width and weight of each of the six test units shall be determined, the length and width to an accuracy of 1.5 mm and the weight to an accuracy of  $\pm 0.5$  percent.

**A-1.2** The thickness of each unit shall be measured to an accuracy of 0.15 mm at six points representing the points of intersection of the diagonals of the six  $20 \times 10$  cm test pieces intended for measurement of the transverse strength. This may be done after the test unit has been marked for cutting or after the test pieces have been cut, whichever is more convenient, provided that the material under test is in a properly conditioned state ( 9.1 ) when the measurements are made.

**A-1.3** The contacting surfaces of the measuring instrument shall be flat and shall have a diameter of at least 9 mm and care shall be taken that

\*Specification for wood wool building slabs ( *under preparation* ).

the surfaces of the board are not deformed when the thickness is measured. The mean of the six measurements shall be deemed to be the thickness of the test unit.

## A-2. DETERMINATION OF DENSITY

A-2.1 The density of each test unit shall be calculated as follows:

$$\text{Density} = \frac{W}{L \times b \times t} \text{ g/cm}^3$$

$$\text{or} = \frac{1\,000\, W}{L \times b \times t} \text{ kg/m}^3$$

where

$W$  = weight of test unit in g,

$L$  = length in cm,

$b$  = width in cm, and

$t$  = mean thickness in cm.

A-2.1.1 The density of each test unit shall be reported together with the average density of all the test units.

## APPENDIX B

( *Clauses 4.2, 8.2 and 9.2* )

### DETERMINATION OF TRANSVERSE STRENGTH

#### B-0. GENERAL

B-0.1 Thirty-six test pieces, each 20 × 10 cm, prepared in accordance with 9.1, shall be used for determining the transverse strength. The test pieces shall be all tested with the same face uppermost.

#### B-1. PROCEDURE

B-1.1 Each test piece shall be simply supported on horizontal parallel rollers having a diameter of 18 to 25 mm spaced at 15 cm centre to centre and free to rotate in ball or roller bearings. The width of the test piece of bitumen fibre insulation board of thickness 18 mm and above shall be 5 cm only. The load may then be calculated and corrected to obtain the load for 10-cm width. A load shall then be applied at the centre of the span along a line parallel to the rollers by means of a bar rounded to a

## IS : 3348 - 1965

radius of 9 to 12 cm. The load is increased at a rate such that the appropriate minimum breaking load, stated in Table 2, is reached in not less than half a minute and not more than four minutes from the commencement of its application.

**B-1.1.1** The following information shall be reported:

- a) The failing load and modulus of rupture of each test piece;
- b) The mean failing load and mean modulus of rupture for the eighteen test pieces marked  $L_1$ ,  $L_2$  and  $L_3$ ; and
- c) The mean failing load and mean modulus of rupture for the eighteen test pieces marked  $X_1$ ,  $X_2$  and  $X_3$ .

NOTE --- Modulus of rupture may be calculated from this information as follows:

$$\text{Modulus of rupture, kg/cm}^2 = \frac{3Wl}{2bd^2}$$

where

- $W$  - failing load in kg,
- $l$  - length of span in cm,
- $b$  = width of test piece in cm, and
- $d$  = thickness of test piece in cm.

## APPENDIX C

( *Clauses 4.3, 8.2 and 9.3* )

### DETERMINATION OF WATER ABSORPTION

#### C-0. GENERAL

**C-0.1** Six test pieces each  $20 \times 10$  cm, prepared in accordance with **9.1**, shall be used in determining the water absorption.

#### C-1. PROCEDURE

**C-1.1** Each test piece shall be weighed to an accuracy of  $\pm 0.5$  g. It shall then be immersed in fresh, clean water, having a pH value of between 6.5 and 7.5 and a temperature of  $27^\circ \pm 2^\circ\text{C}$ , the water being renewed before each test. The test pieces shall be immersed in such a way that they are horizontal, clear of the bottom of the tank, and covered by approximately 25-mm layer of water. After two hours of immersion, they shall be withdrawn from water and after wiping off any excess of water with a damp cloth, each test piece shall be reweighed to an accuracy of  $\pm 0.5$  g.

**C-1.1.1** The following information shall be reported:

- a) The water absorbed by each test piece expressed as a percentage of its weight before immersion, and
- b) The mean percentage water absorption of the six test pieces.

## APPENDIX D

( Clauses 4.4, 8.2 and 9.4 )

### METHOD OF TEST FOR THERMAL CONDUCTIVITY

#### **D-0. GENERAL**

**D-0.1** Either of the methods covered in **D-2** and **D-3** may be used for determining thermal conductivity.

#### **D-1. PREPARATION OF TEST SPECIMENS**

**D-1.1** One test piece from each sample shall be cut away from the end of the sample by 15 cm unless the size of the board is such that the sample has to be cut nearer to the edge. The size of the sample shall be 30 × 30 cm and the full thickness of the board.

**D-1.2 Measurement of Thickness of Specimens** — The thickness of specimen shall be measured at a number of places for finding the average. The thickness may also be found by measuring the area of the specimen and also the volume of the specimen after the test by immersing in water.

**D-1.3** Test specimens shall be conditioned to a uniform moisture according to **3.2.1** of IS : 2380-1963\*.

**D-1.4** The minimum thickness of the board in between the plates shall be 24 mm. In case the thickness of the board is less than this, two or three boards shall be used together, placed one over the other, to make the thickness minimum 24 mm.

#### **D-2. METHOD I ( GUARDED HOT-PLATE METHOD USING TWO SLABS )**

**D-2.1** This shall be done using the apparatus and following the procedure specified in IS : 3346† maintaining the temperatures of the hot-plate and cold-plate respectively at 30° and 25°C.

**NOTE** — Till IS : 3346† is published, the method shall be subject to agreement between the concerned parties.

\*Method of test for wood particle boards and boards from other lignocellulosic materials.

†Method for the determination of thermal conductivity of thermal insulating materials ( two-slab, guarded hot-plate method ) ( *under preparation* ).

## IS: 3348 - 1965

**D-2.2 Calculation** — The test area shall be calculated from the centre of one separation to the centre of the other separation across the central surface of the plate. The thermal conductivity shall then be calculated from the following formula:

$$K = \frac{q \times L}{A (t_1 - t_2)}$$

where

- $K$  = thermal conductivity in kcal·cm/cm<sup>2</sup>·h°C,
- $q$  = time rate of heat flow area [  $A$  ( kcal/h ) ],
- $L$  = length of path of heat flow ( thickness of specimen )  
in cm,
- $A$  = area normal to heat flow ( m<sup>2</sup> ),
- $t_1$  = temperature of hot surface ( °C ), and
- $t_2$  = temperature of cold surface ( °C ).

## D-3. METHOD II ( GUARDED HOT-PLATE METHOD USING SINGLE SLAB )

**D-3.1 Apparatus** — The apparatus shall be as shown in Fig. 2. It shall consist of the cold-plate on which specimen to be tested is placed and a hot-plate of about 10 cm diameter. The guard ring shall be shaped like a dome and shall be maintained at the same temperature as the hot-plate. The space between the upper surface of the hot-plate ( which is also insulated ) and inner surface of the top of the guard dome being filled with air. A bell jar of suitable size shall also be available to enclose the hot-plate, guard dome and the specimen whenever required, so that by means of suitable hot solutions placed inside the bell jar, it will be possible to maintain any humidity corresponding to the moisture content of the specimen. The hot-plate shall be made of copper.

**D-3.1.1 Measurement of Temperature** — The hot-plate temperature shall be measured with the three thermocouples, one embodied in the centre of the plate and the other two on the points on either side of the centre on a diameter. The guard dome temperature shall be measured at three points at the apices of an equilateral triangle, two of these by means of thermocouples and the third with a thermometer thus including a check on the measurement. The cold-plate temperature shall be likewise measured by means of suitably located thermocouples.

**D-3.1.1.1** For the temperature measurements, obliterated soft soldered manganin constantan thermocouples ( 0.3 mm diameter ) shall be used. The measurement of temperature shall be accurate to 0.01°C.

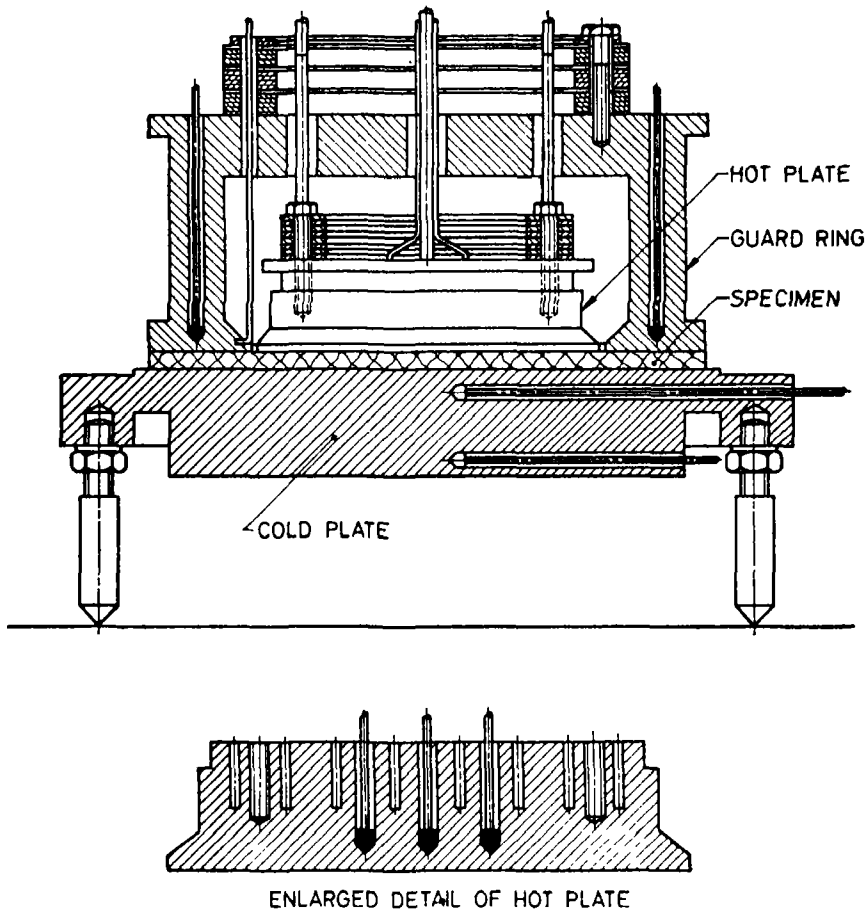

FIG. 2 GUARDED HOT PLATE APPARATUS FOR MEASURING THERMAL CONDUCTIVITY (METHOD II)

**D-3.1.2 Measurement of Energy**—The energy supplied for heating the hot-plate shall be measured with suitable precision instruments so that the measurement of energy is accurate to 0.2 percent.

**D-3.2 Procedure**—Put the specimen in the apparatus and also the thermocouples and supply heat from time to time so that the desired temperature is attained in the hot-plate. Care shall be taken not to keep the plate above the desired temperature and it is preferable if the plate is brought up to that temperature slowly. The temperature of the guard dome shall also be brought to the same value as that of the hot-plate by

**IS : 3348 - 1965**

adjustment of the current in its heating coil. The apparatus shall then be left undisturbed with a constant energy input for some time. Readings shall be taken for temperature, current and energy at every 15 minutes or half-an-hour till after about two hours when they become constant.

**D-3.3 Calculation** — The thermal conductivity shall be calculated in the same manner as in **D-2.2**.

## **A P P E N D I X E**

( *Clauses 5.1, 8.2 and 9.6* )

### **METHOD OF TEST FOR SURFACE SPREAD OF FLAME**

#### **E-1. SCOPE**

**E-1.1** This method covers inclined panel flame tests on insulation board to determine the area of char of the finished surface and duration of flaming.

#### **E-2. APPARATUS AND MATERIALS**

**E-2.1 Specimen Support** — Suitable means shall be provided for supporting the specimen during the test at an angle of 45°, with the upper and lower edges of the plane of support being horizontal. This may be accomplished by resting the specimen on four points; but it is necessary, whatever method of support be employed, that (a) the central portion of the specimen shall not be shielded from the flame, (b) the supports shall not prevent access of air for combustion, and (c) the apparatus shall be such that the progress of the test can be observed. A suitable apparatus is shown in Fig. 3.

**E-2.2 Flame Source** — A flat bottomed cup of 2.2 mm in internal diameter and 7 mm in depth shall be placed on a support composed of corkboard. The cup shall be made of sheet iron about 0.8 mm thick. It shall be supported so that the centre of its base is 25 mm vertically below a point on the lower surface of the test specimen, 75 mm from its lower horizontal edge, and midway between the inclined edges.

**E-2.3 Alcohol** — Absolute ethyl alcohol conforming to IS : 321-1964\*.

#### **E-3. TEST SPECIMENS**

**E-3.1** Three 30 × 30 cm specimens, one each from the sample from three boards, shall be tested.

---

\*Specification for absolute alcohol (*retised*).

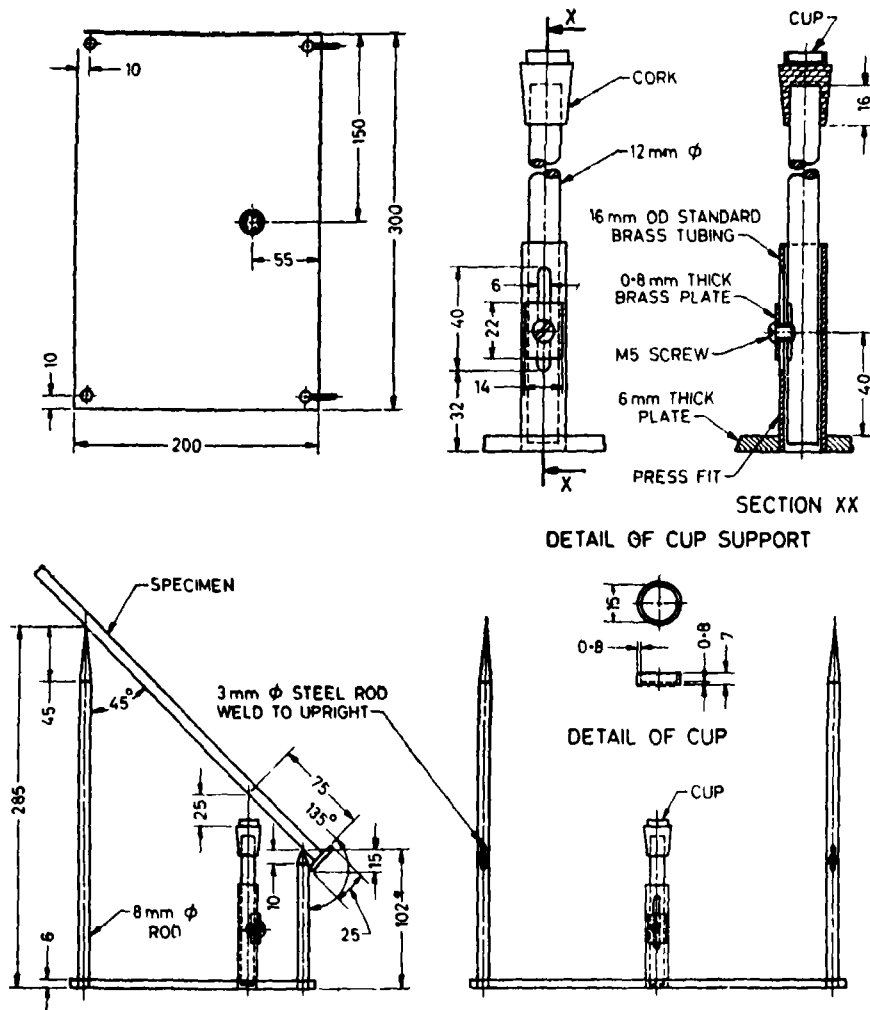

All dimensions in millimetres.

FIG. 3 TESTING FIBRE INSULATING BOARD FOR SURFACE SPREAD OF FLAME

#### E-4. PROCEDURE

**E-4.1** Condition each specimen until equilibrium is obtained at a temperature of  $27^{\circ} \pm 2^{\circ}\text{C}$  and a relative humidity of  $65 \pm 5$  percent.

**IS : 3348 - 1965**

**E-4.2** Place the specimen on the test apparatus. Place 1 ml of absolute ethyl alcohol in the cup from a suitable pipette or other means and ignite (with the test specimen in place) by a small gas or oil jet or other suitable small source of heat, which shall be removed as soon as the alcohol is lighted. The cup shall be at room temperature before each test. The test shall be made in a draft-free room or enclosure with a subdued light.

**E-4.3** One minute after the fuel has been exhausted, extinguish any flame and glow on the specimen, and determine the area of char. If the duration of flaming is less than 1 min, extinguish any smoldering, and measure the area of char. Determine the area of char by cutting slots approximately along the major and minor axes of the elliptical char area to a depth sufficient to expose the board structure below the coating. Determine the length of these axes by taking the terminal of each line end as that point where a definite charring or decomposition of the fibre structure has first taken place.

**E-5. CALCULATION AND REPORT**

**E-5.1** Using the major and minor axes,  $a$  and  $b$ , of the area of char determined in accordance with **E-4.3** as those of a true ellipse, calculate the area of char as follows:

$$\text{Area of char} = \frac{\pi ab}{4}$$

**E-5.2** Report the area of char and the duration of flaming taking the average of the three specimens as the average of the lot.

## BUREAU OF INDIAN STANDARDS

### Headquarters:

Manak Bhavan, 9 Bahadur Shah Zafar Marg, NEW DELHI 110002

Telephones 323 0131, 323 8375, 323 9402

Fax 91 11 3234062, 91 11 3239399

Telegrams Manaksanstha  
(Common to all Offices)

### Central Laboratory:

Plot No 20/9, Site IV, Sahibabad Industrial Area, Sahibabad 201010

Telephone  
8-77 00 32

### Regional Offices:

Central Manak Bhavan, 9 Bahadur Shah Zafar Marg, NEW DELHI 110002	323 76 17
*Eastern 1/14 CIT Scheme VII M, V I P Road, Maniktola, CALCUTTA 700054	337 86 62
Northern SCO 335-336, Sector 34-A, CHANDIGARH 160022	60 38 43
Southern C I T Campus, IV Cross Road, MADRAS 600113	235 23 15
†Western Manakalaya, E9, Behind Marol Telephone Exchange, Andheri (East), MUMBAI 400093	832 92 95

### Branch Offices:

'Pushpak', Nurmohamed Shaikh Marg, Khanpur, AHMEDABAD 380001	550 13 48
‡Peenya Industrial Area, 1st Stage, Bangalore-Tumkur Road, BANGALORE 560058	839 49 55
Gangotri Complex, 5th Floor, Bhadrabhadra Road, T T Nagar, BHOPAL 462033	56 40 21
Plot No 62-63, Unit VI, Ganga Nagar, BHUBANESHWAR 751001	40 36 27
Kalakathar Buildings, 670 Avinashi Road, COIMBATORE 641037	21 01 41
Plot No 43 Sector 16 A, Mathura Road, FARIDABAD 121001	8-28 88 01
Savitri Complex, 116 G T Road, GHAZIABAD 201001	8-71 19 96
53/5 Ward No 29, R G Barua Road, 5th By-lane, GUWAHATI 781003	54 11 37
5-8-56C, L N Gupta Marg, Nampally Station Road, HYDERABAD 500001	20 10 83
E-52, Chitaranjan Marg, C-Scheme, JAIPUR 302001	37 29 25
117/418 B, Sarvodaya Nagar, KANPUR 208005	21 68 78
Seth Bhavan, 2nd Floor, Behind Leela Cinema, Naval Kishore Road, LUCKNOW 226001	23 89 23
Patliputra Industrial Estate, PATNA 800013	26 23 05
TC No 14/1421, University PO Palayam, THIRUVANANTHAPURAM 695034	6 21 17
<b>Inspection Offices (With Sale Point)</b>	
Pushpanjali, 1st Floor, 205-A, West High Court Road, Shankar Nagar Square, NAGPUR 440010	52 51 71
Institution of Engineers (India) Building, 1332 Shivaji Nagar, PUNE 411005	32 36 35

\*Sales Office is at 5 Chowringhee Approach, PO Princep Street,  
CALCUTTA 700072 27 10 85

†Sales Office is at Novelty Chambers, Grant Road, MUMBAI 400007 309 65 28

‡Sales Office is at 'F' Block, Unity Building, Narashimaraja Square,  
BANGALORE 560002 222 39